



## 2024 Hornet/Youth Hornet Rules

Evergreen Speedway, Monroe, WA

(Updated 11/8/2023)

### **Rule Book Disclaimer**

The rules and regulations are designed to provide for the orderly conduct of racing events and to establish minimum acceptable requirements for such events. These rules shall govern all events, and by participating in these events. All participants are deemed to be in compliance with these rules and regulations. All rules are subject to the interpretation of the track officials. Any equipment that the officials consider exotic or not in the interest, or intent of the rules will be considered not legal for competition.

### **NO EXPRESS OR IMPLIED WARRANTY OF SAFETY SHALL RESULT FROM PUBLICATIONS OF OR COMPLIANCE WITH THESE RULES AND/OR REGULATIONS.**

These rules are intended as a guide for the conduct of the sport and are in no way a guarantee against injury or death to a participant spectator official or others. The Tech Director shall be empowered to permit minor deviations from any of the specifications or impose further restrictions that, in his opinion, do not alter the minimum acceptable requirements.

### **NO EXPRESSED OR IMPLIED WARRANTY OF SAFETY SHALL RESULT FROM SUCH ALTERATIONS OF SPECIFICATIONS.**

Interpretation of, or deviation from these rules is left to the discretion of the Officials. Their decision is final. It's the responsibility of the driver to ensure their car conforms to all rules and regulations at all times.

### **Explanation:**

The hornet division is designed to promote a greater interest in stock car competition. It is designed to allow new and inexperienced drivers and owners to become familiar with short track racing while competing against drivers of all skill levels. This class enables individuals with moderate means to participate without spending a significant amount of money for race equipment. Decisions and interpretations of the rules by the Tech Director shall be final. The Tech Director reserves the right to issue penalties to equalize competition. **No alterations from stock production automobiles except as listed in these rules are allowed.** If it doesn't say you can, you can't

### **Explanation:**

The Youth Hornet division is designed to promote a greater interest in stock car competition in 12- to 14-year-old. It is designed to allow new and inexperienced drivers and owners to become familiar with short track racing while competing against other drivers of the same age group. It is open to all competitors that are a minimum of 12 years of age and a maximum of 14 years of age the first time they compete. Drivers turning 15 during a season they are competing in are allowed to finish out the current season.

### **DEFINITIONS:**

"OEM" as used in this document is defined as Original Equipment Manufacturer. This is further defined as a part that meets all factory original specifications for the vehicle as it was sold new even if the replacement part is produced by a vendor other than the original vehicle manufacturer. "OEM fit", "OEM Compatible", "OEM Replacement" or other similar descriptions are not necessarily a direct OEM replacement.

Email [kevin@evergreenspeedway.com](mailto:kevin@evergreenspeedway.com) with any questions you have about specific cars or components.

## 1. COMPETING MODELS

1. 4-cylinder factory production USDM cars that meet the following specifications. Some cars that were available in limited production, were factory "race prepped" or are newer than 2001 are not within the intended scope of this class. Please contact the track before investing time and money into a build to be sure the car you are choosing is allowed.
2. Maximum factory advertised wheelbase of 106.5"
3. Must carry an EPA class designation of "Compact" "Minicompact" or "Subcompact" Search online if you are unsure of your car's class
4. No cars with rotary engine, turbocharger, all-wheel drive, 4-wheel steering, supercharger or other factory performance enhancements are allowed. This subsection is intended to cover all factory performance parts including but not limited to headers, LSD differentials, Adjustable suspension parts. These parts are not within the intended scope of this class. Parts that were available only on limited production trim levels and/or were not available in the USDM are not within the intended scope of this class.

## 2. BODY AND CAR PREPARATION

1. Interiors of cars must be stripped of all flammable materials. OK to leave factory gauge cluster in. No cockpit style interiors allowed.
2. All exterior molding, trim and lighting must be removed
3. All glass except the front windshield must be removed. Windshield may be replaced with 1/8" Lexan. Lexan must be securely attached and have two vertical braces in the center of the windshield. Braces must be securely attached.
4. Steering wheel may be replaced with a quick release style. Highly Recommended.
5. Pedals must remain completely stock for make and model of car.
6. Dashboard optional. If metal part of dash is modified or removed, a dash bar must be installed. Dash bar must run over the top of the steering column.
7. All insulation under the hood must be removed
8. Battery must be securely fastened. May be relocated to passenger compartment. Must be fully enclosed in a battery box. Box must be securely mounted to floor or cage.
9. Battery master disconnect is required. Must cut all power to electrical system. Must kill the engine when switched to the off position.
10. Roll Over Protection.
  - a. For races on the 1/5 mile, the boot, and the road course the minimum protection shall be a door bar of 4" channel extending 4" past the front and rear door seams on both sides of the car.
  - b. A vertical roll over post behind the driver's seat. Minimum of 3"x 3" round or rectangular tubing with a minimum of 6"x6" x 1/4" thick square plate welded at each end. A 6"x6" x 1/4" plate must also be used on top of the roof and under the floorboard to hold the rollover bar in place. Each plate must be secured with a minimum of (4) four 1/2" grade 8 bolts
  - c. A crossbar must attach to the exterior door bars. It must extend across the interior of the car from side to side behind the driver's seat. Minimum of 3"x 3" round or rectangular tubing with a minimum of 4"x4" x 1/4" thick plate welded at each end. A minimum of (4) four 1/2" grade 8 bolts must secure the crossbar to the outside door bars. Must also be welded to the vertical roll over post behind the driver's seat.
  - d. A cage is highly recommended. See addendum for acceptable designs.
    - a. Driver's door bars must be covered with a minimum of 11-gauge magnetic steel sheet.
    - b. Outside door bars are allowed on caged cars but must meet the following criteria

- i. They must be flush mounted to the body
- ii. They must be tapered and/or capped on each end.
- iii. They cannot be tied/bolted or touching the roll cage in any way.
- iv. They must extend in front of the A-pillar and behind the B-pillar
- v. They must be bolted through the body as close to the ends as possible with backer plates

11. Spec Bumper.

- a. See drawings on the last page. The bumper may be welded to a maximum of (1) 3/16" thick plate attached to the end of the horns or have a 3/16 "maximum thick plate welded to the end of the horns and one welded to the bumper bracket as pictured and then bolted. No other attachment points allowed.
- b. Bumper cannot be used to strengthen the car.
- c. Cars that have bumpers with excessive bracing (as determined by the Tech Inspector) will not be allowed to compete.

- 12. Car numbers on doors must be at least 16" tall and must be easy to read from the tower. Roof number must be at least 22" in height. Use contrasting colors for your numbers. No Chrome. If we can't read your numbers from the tower, you will not be scored.
- 13. All doors must be welded, chained, or bolted shut.
- 14. It is encouraged to build fan recognition of drivers that cars be painted neatly and brightly.
- 15. NO ADDED ROCKER PANELS.
- 16. NO Aftermarket Nose Pieces.
- 17. Repairs to core supports, radiator mounting points, bumper mounting areas etc. Must be done with materials similar in strength to factory. Box tubing frames that connect the frame horns together and strengthen the nose of the car will be dealt with on a case-by-case basis. Tech Officials may require cutting, drilling or material removal. Their decision is final.

### 3. FUEL SYSTEM AND ENGINE CONTROLS

- 1. Stock carburetor or fuel injection for Make, model, and year of car being raced. No modifications allowed
- 2. Factory gas tank may be used as long as it remains mounted in its factory location AND is located ahead of the rear wheels. Racing style fuel cell highly recommended for all cars.
- 3. Racing style fuel cell is required for any car that doesn't meet section 2. above.
- 4. Fuel cell must be covered, secured, and located in the trunk area.
- 5. Electric fuel pumps located outside of fuel tank must be firewalled from the driver's compartment. High pressure fuel line must be used. Fuel lines must be double clamped.
- 6. ECM and wiring harness must be stock for engine being used. No modification, programming, flashing etc.

### 4. ENGINE, TRANSMISSION, EXHAUST AND WEIGHT

*Minimum car weights are being established in an effort to equalize competition in the Hornet class at Evergreen Speedway. All weights are with driver and subject to adjustments at future dates if deemed necessary by the Officials. Individual car weight adjustments are at the sole discretion of the Tech Director.*

1. **Weights:**

- a. 135 or less factory advertised horsepower: No minimum weight
- b. 136 to 159 factory advertised horsepower: 2300 lbs.
- c. 160 to 189 factory advertised horsepower: 2400 lbs.
- d. 190 to 200 factory advertised horsepower: 2500 lbs.
- e. Over 200 horsepower **not allowed.**

- 2. All factory engine specifications including horsepower rating will be determined by using engine family and model numbers and referencing manufacturer marketing and technical data.
- 3. All added weight to meet these requirements must be declared to Tech officials.
- 4. All added weight must be secured to the car with a minimum of (2) 1/2 "Grade 8 bolts with backing plates if

needed.

5. 50% (one half) of all added weight must be secured to the car on the right side, midway between the front and rear tires. It must be located as far to the right as possible and still be able to securely mount it. The other 50% of added weight may be distributed at car owner's discretion.
6. All added weight must be secured and, in a location, deemed safe by Evergreen Tech.
7. All added weight must be in 5 lb. minimum blocks, painted white and have the car number on it.
8. Engine must be a stock replacement for make, model, and year. JDM replacement engines must be declared to Tech before competing in any event. JDM engines will be handled on a case-by-case basis and penalties may be assigned.
9. No modifications from factory components other than those required for repair to factory specs. No boring of cylinders. Head surfacing allowed. Compression ratio must stay within 2 tenths of factory advertised ratio.
10. Transmission must be stock for make, model and year of car being raced. Cars with factory LSD style differential must be declared at tech before competing in any event. Weight penalty for LSD differential is 300 lbs. NO AFTERMARKET LSD ALLOWED. Transmission gearing and/or differential ratios may not be changed. Transmissions that are considered rare or were not commonly available in the year/make/model (as decided the Lead Technical Inspector) are considered to be out of the intended scope of this class.
11. Rear wheel drive cars must run stock unaltered rear end for the year, make & model.
12. Stock style muffler is mandatory. Universal mufflers, such as the Walker 17881 are recommended. 1 3/4" maximum pipe size. No cherry bomb style mufflers allowed. Exhaust system must exit out the rear of the car. Must be securely mounted. This rule is intended to make the cars exhaust close to the factory sound. Tech will make the final decision on whether the noise level from the car is acceptable. Their decision is final and refusal to comply will result in not being allowed to race.

## 5. SUSPENSION

1. Camber on any tire is not to exceed 3/4" from vertical as measured by officials. No aftermarket adjustable parts allowed. No cutting or modifying any mounting points or control arms
2. Any car with a factory ride height less the 5" must receive approval from the lead technical inspector before competing. No new builds allowed
3. No modifications to any steering components allowed.
4. Springs must be OEM for the Make, model, and year of car. No aftermarket or rated springs allowed. No rear springs in the front and no front springs in the rear. No Progressive Springs stock or otherwise allowed.
  - a. Springs cannot be cut or modified in any way
5. Must run stock or direct OEM style replacement struts and/or shocks. Must be bolted on as the car came from the factory. No Spacers or shims.
6. No Bump Stops, Factory or otherwise that limit suspension travel. No Limiting suspension travel in any way. All suspension must move freely.
7. Front and rear strut tower braces are allowed. Homemade strut tower braces are allowed. Must be a single brace made from a maximum of 1 1/2" tubing.

## 6. TIRES, WHEELS & BRAKES

1. Any manufacturer's DOT approved passenger car tire that meets the following criteria:
  - a. Must be 60 series or larger.
  - b. Must be 400 or higher treadwear.
  - c. Speed rating of H or less.
  - d. Be commercially available for purchase for less than \$95.00 each including shipping. Excludes closeouts, discontinued or other discounts not available to all racers.
  - e. Each tire must have tread showing across the complete face of the tire.
2. No tire softener allowed.
3. No slotted or drilled brake rotors. No modifications to factory braking system except ABS disabling.

4. Factory wheels only. Maximum 6" width.
5. No wheel weights allowed.
6. No wheel spacers allowed.

## **7. SAFETY**

1. Racing style seat is mandatory. No stock seats
2. Seat must be securely mounted. NO sliding mounts allowed
3. 5-point racing style harness in good condition required. Subject to tech.
4. Fire rated driver's suit is required. Multi-layer suits with racing gloves and shoes highly recommended.
5. **Snell SA2015 or newer will be required for the 2024 season.**
6. Driver's door window net is required. It must be SFI approved and in good condition. Must be securely mounted on the bottom and have a quick release latch at the top.
7. Must have a fire extinguisher mounted in car within easy reach of the driver. Must be secured properly. No zip ties, straps or tape holding it in.

## **8. GENERAL**

1. No in car communications systems (radios, cell phones etc.) unless required by Evergreen Speedway Officials.
2. Raceceivers tuned to the track frequency are MANDATORY
3. All cars are required to run a scoring transponder any time the car is on the track including all practice sessions.

## **9. SEASON POINTS and LINE-UPS**

1. Points will be issued for qualifying using the following format
  - a. 1<sup>st</sup> 8 points
  - b. 2<sup>nd</sup> 6 points
  - c. 3<sup>rd</sup> 5 points
  - d. 4<sup>th</sup> 4 points
  - e. 5<sup>th</sup> 3 points
  - f. 6<sup>th</sup> 2 points
  - g. 7<sup>th</sup> and back 1 point
2. Heat Races and Main Events will be lined up by qualifying times.

## **GENERAL INFORMATION**

All participants are expected to take pride in being part of our entertainment. Racing entertainment is what we sell to the public and we will not tolerate anyone or anything that detracts from the show. Cars in the opinion of the Officials that lack in appearance or are deemed unsafe will not be allowed to race until acceptable. All car construction rules will be decided by NASCAR tech inspectors. Burden of proof on any concern will be the responsibility of the driver.

**ALL NUMBERS WILL BE ASSIGNED BY THE SPEEDWAY OFFICE (360) 805-6100 AND MUST BE RENEWED EVERY YEAR.**

## **WHAT TO DO IF YOU ARE INJURED IN AN ACCIDENT AT EVERGREEN SPEEDWAY**

1. Have the ambulance attendant check you out and fill out an accident report.
2. GET MORE MEDICAL ATTENTION IF NECESSARY.
3. **Inform the Speedway office if you need to open a claim.**
3. If you have follow-up treatments, please advise your doctor of the following
  - a. Your insurance carrier
  - b. NASCAR insurance claim number

- c. The date of the accident
  - d. The time and place of your accident
4. Your doctor should then bill NASCAR directly.

**It is the responsibility of the driver to ensure their car confirms to all rules and regulations at any time while on the racing surface or anywhere on premises. This includes practice, qualifying and competitive racing.**

©2024 Evergreen Speedway. All Rights Reserved

Cages must be built out of 1 1/2 "or 1 3/4" ERW or DOM Tubing. Minimum wall thickness of .095

### **Option 1**



Door bars and overhead welds must be gusseted.

### **Option 2**



Door bars, passenger side "X" and overhead welds must be gusseted.

Spec Bumper is to be made from 1 1/2" .095 Round Tubing Only.



### Spec Bumper Mounting Bracket

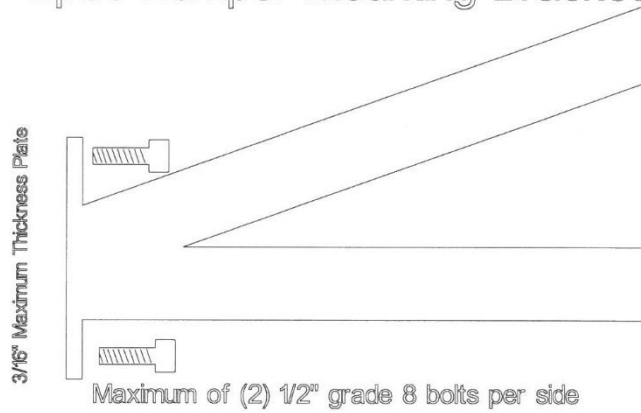

- (1) Bracket per side of the car. Wrap around bars may circle around and be welded to the frame horn. No other bracing is allowed. Mounting bracket must also be made of 1 1/2" x .095 round tubing.